

ER Indexable Cutter >>>

ERgo just say "ergo".

The Ergo is a new trademark of Nine9 for ER type indexable cutter. Better rigidity, quick change, excellent repeatability, tool length maintain, and pre-balanced.



▶ **3 Different Sizes Of Integrated ER Taper-Shank Cutter**

- ER11 / ER16 / ER20



Concept >>>

- ▶ **An Integrated ER Taper-Shank Cutter, Eliminate Assembly Tolerance.**
- ▶ **A Clamping Force Gained From The 3 Parts Including Ergo Nut, High Strength Ergo Pin And ER Taper.**
- ▶ **Ergo Nut Drives The Pin To Push Ergo Holder Into ER Taper. It Is " A simple way to maximize clamping force "**
 - Short tool length and quick change system for adapting on small working area.
 - Ideal solution for BT30, driven tools, tapping and turning center.
 - Increase tool life.
 - Easy and simple assembly.
- ▶ **Ergo Provide Customized Tooling Service.**



Applications

OAL: 33.5mm (1.319") Group

Tool Length Setter

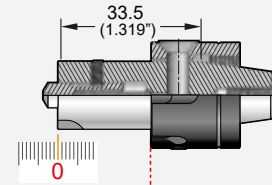

Multi-Functional Tool

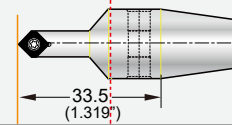

Engraving & Deburring

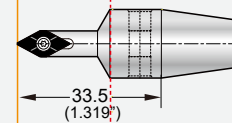

Chamfer Mill

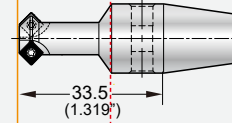

OAL: 26mm (1.024") Group

Power Mill Ø10 ~ Ø32mm

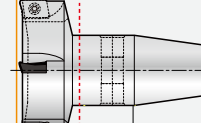
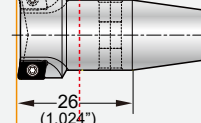
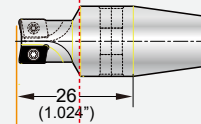

OAL: 56.5 (2.224")mm

i-Center

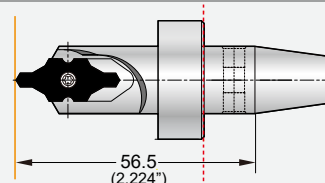

Quick Change, Saving Huge Machine Downtime.













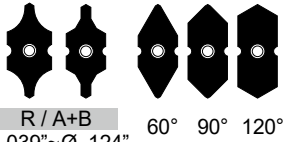
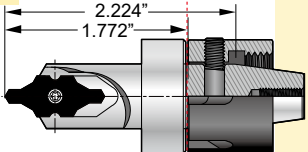



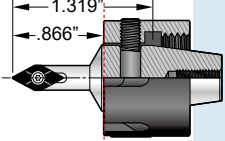

- The simplest way to get tools on the machine.
- 3 fixed tool length groups of Ergo system.
- No need to reset tool length while changing tools in the same group.

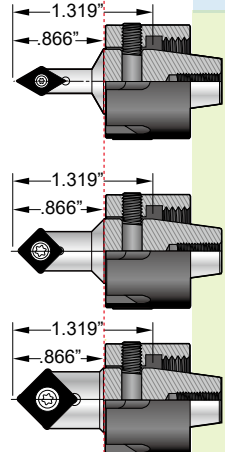

“ The Ergo system includes milling cutter, spot drills, engraving tools, deburring tools, chamfering tools, and center drills. ”

5

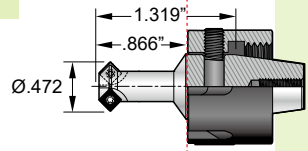
Ergo

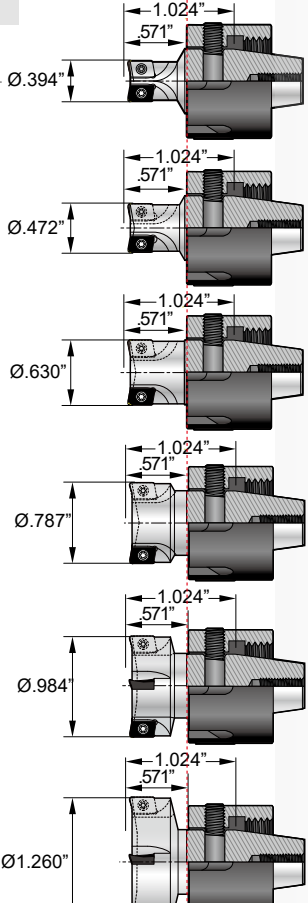
<p>ER16</p>	<p>i-Center Internal coolant G6.3 10,000 r.p.m.</p>	 <p>Centering DIN 332 R DIN 332 A+B</p>  <p>Spotting & Csink 60°, 90° & 120°</p>	<p>I9MT1003</p>  <p>R / A+B 60° 90° 120° Ø .039"~Ø .124"</p>	 <p>2.224" 1.772"</p>
<p>ER16</p>	<p>X060 G4.0 20,000 r.p.m.</p>	 <p>Spotting/Engraving 30° ~ 142°</p>  <p>Deburring 60° & 90°</p>	<p>X060</p>  <p>30° 45° 60° 90° 120° 142° 60° 90°</p>	 <p>1.319" .866"</p>
<p>ER16</p>	<p>Multi-Functional Tool G6.3 10,000 r.p.m.</p>	 <p>Spotting</p>  <p>Chamfering</p>	<p>V060</p>  <p>60°</p> <p>N9MT0802</p>  <p>90°</p> <p>N9MT11T3</p>  <p>90°</p>	 <p>1.319" .866"</p>
<p>ER16</p>	<p>Chamfer Mill G6.3 10,000 r.p.m.</p>	 <p>Front & Back Chamfering</p>  <p>Face Milling</p>	<p>N9GX04T002</p>  <p>45°</p>	 <p>1.319" .866" Ø.472"</p>
<p>ER11</p> <p>ER16</p> <p>ER20</p>	<p>Power Mill G6.3 10,000 r.p.m.</p>	 <p>Ø .394" Ø 1.260"</p> <p>Smaller, sharper and more effective teeth.</p>	<p>A9GT0602</p>  <p>Re .004" Re .008" & Re .020"</p>	 <p>1.024" .571" Ø.394" Ø.472" Ø.630" Ø.787" Ø.984" Ø1.260"</p>

99816-IC10BH
OAL
||
2.224"

99816-X060

99816-V060

99816-610

OAL
||
1.319"

99816-614

99816-C10

99816-10A06

99816-12A06

99816-16A06

OAL
||
1.024"

99816-20A06

99816-25A06

99816-32A06

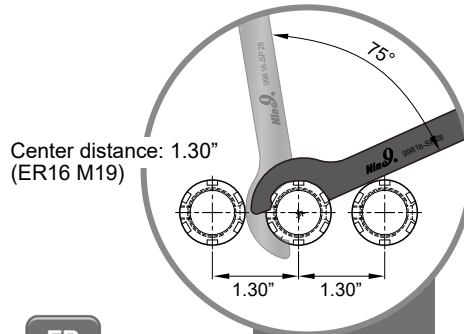

ER 11

ER 16

ER 20

Pin & Nut
are sold separately.

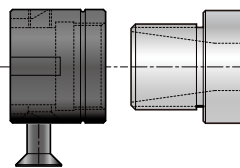

Ergo system can apply on live spindle tool of turning centers and swiss type automatic lathes, such as Star, Citizen, Doosan, Tsugami, Tornos, INDEX, EMAG...and so on. And also good for tapping and machining centers.

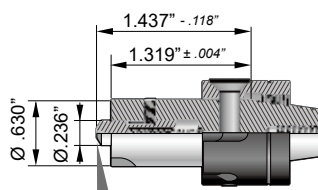
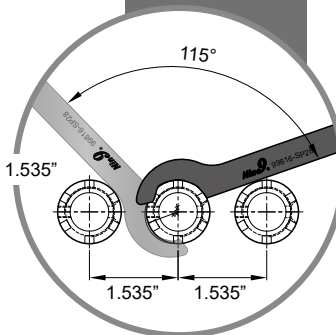

Spring Pin

Ergo
Setter TP
99816-TP





5

Ergo

Ergo's Features



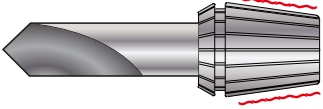

► Optimize the rigidity >>

- An integrated ER taper- shank cutter, eliminate assembly tolerance.
- Pre-balanced, ready for high speed machining. Increase tool life.

Ergo Integrated design	Cutting tool + Spring collet
  <ul style="list-style-type: none"> • Improve tool concentricity • Increase rigidity 	  <ul style="list-style-type: none"> • When tightening ER nut, be cautious of uneven tightening situation. • Chips, rust, or collet deform.

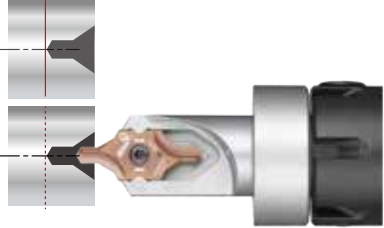

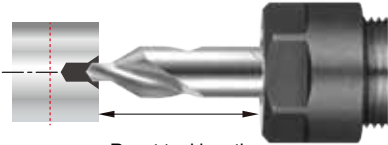

► Excellent repeatability, saving set-up time >>

- The greatest benefit is saving the tool changing time and tool length setting time.
- The drilling depth is constant after change the insert or cutting edge.

Ergo indexable cutter	Solid carbide center drill
 	 <p>Reset tool length every time after tool changed</p> 

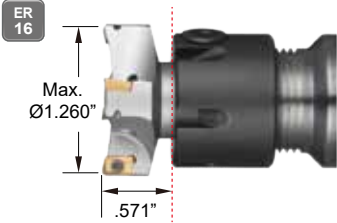

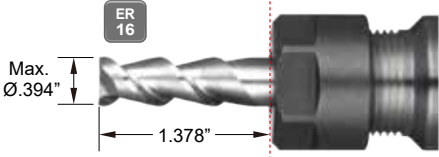
► Dimension is not limited by the ER16 collet clamping range >>

- Cover milling cutter range from $\varnothing 10$ to $\varnothing 32\text{mm}$ ($\varnothing .394\text{"} \sim \varnothing 1.260\text{"}).$
- More efficiency and the possibilities to cut bigger parts.
- The shorter tool length, the better run-out accuracy.

Ergo indexable cutter	Solid carbide end mill
 	 

► Easy and simple assembly >>

- A simple Ergo cutter has minimal assemble parts, saving 50% your time.
- Thanks to ER taper, the repeatability of assemble tolerance is $\pm 0.1\text{mm}$ ($.0039\text{"})$ while changing same tool length of Ergo holder.

Ergo cutter	Solid carbide cutter
 	 

i-Center Indexable Center Drill

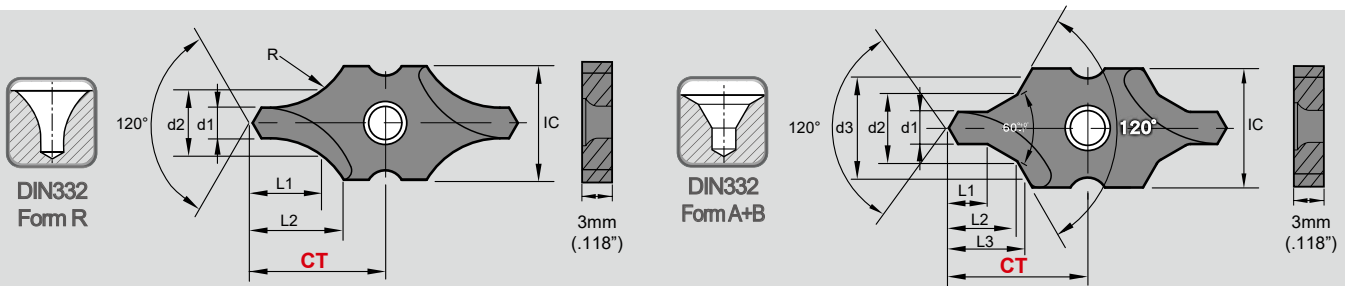

► For DIN332 Form R Center Hole >>

IC	Parts No.	Coating	Grade	d1	d2	L1	L2	R	CT ±0.025 (.001")	
10 (.394")	I9MT1003R0100-NC2057	AlTiN+ TiSiN	P35	1.00 (.039")	2.12 (.083")	2.16 (.085")	4.72 (.186")	2.80 (.110")	12.35 (.486")	
	I9MT1003R0125-NC2057			1.25 (.049")	2.65 (.104")	2.74 (.108")	5.22 (.206")	3.50 (.138")		
	I9MT1003R0150-NC2057			1.50 (.059")	+0.14 (.006") 0	3.60 (.142")	3.67 (.144")	6.14 (.242")		5.00 (.197")
	I9MT1003R0160-NC2057			1.60 (.063")		3.35 (.132")	3.45 (.136")	5.32 (.210")		4.50 (.177")
	I9MT1003R0200-NC2057			2.00 (.079")	4.25 (.167")	4.45 (.175")	6.50 (.256")	5.65 (.222")		
	I9MT1003R0250-NC2057			2.50 (.098")	5.30 (.209")	5.59 (.220")	7.66 (.302")	7.15 (.281")		
	I9MT1003R0300-NC2057			3.00 (.118")	+0.18 (.007") 0	5.70 (.224")	6.92 (.272")	9.50 (.374")		10.00 (.394")
	I9MT1003R0315-NC2057			3.15 (.124")		6.70 (.264")	7.21 (.284")	8.93 (.352")		9.00 (.354")

► For DIN332 Form A+B Center Hole >>

IC	Parts No.	Coating	Grade	d1	d2	d3	L1	L2	L3	CT ±0.025 (.001")	
10 (.394")	I9MT1003B0100-NC2057	AlTiN+ TiSiN	P35	1.00 (.039")	2.12 (.083")	3.15 (.124")	1.3 (.051")	2.21 (.087")	2.51 (.099")	12.35 (.486")	
	I9MT1003B0125-NC2057			1.25 (.049")	2.65 (.104")	4.00 (.157")	1.6 (.063")	2.75 (.108")	3.14 (.124")		
	I9MT1003B0150-NC2057			1.50 (.059")	+0.14 (.006") 0	3.18 (.125")	4.50 (.177")	2.0 (.079")	3.45 (.136")		3.84 (.151")
	I9MT1003B0160-NC2057			1.60 (.063")		3.35 (.132")	5.00 (.197")	2.0 (.079")	3.46 (.136")		3.93 (.155")
	I9MT1003B0200-NC2057			2.00 (.079")	4.25 (.167")	6.30 (.248")	2.5 (.098")	4.39 (.173")	4.98 (.196")		
	I9MT1003B0250-NC2057			2.50 (.098")	5.30 (.209")	8.00 (.315")	3.1 (.122")	5.53 (.218")	6.28 (.247")		
	I9MT1003B0300-NC2057			3.00 (.118")	+0.18 (.007") 0	6.46 (.254")	9.00 (.354")	4.1 (.161")	7.10 (.280")		7.83 (.308")
	I9MT1003B0315-NC2057			3.15 (.124")		6.70 (.264")	10.0 (.394")	3.9 (.154")	6.90 (.272")		7.85 (.309")



► Basic Holder >> • G6.3 / 10,000 r.p.m. • With internal coolant.

IC	Parts No.	Basic Holder	L1	øD	Screw	Key
10 (.394")	99816-IC10BH		16 (.630")	45 (1.772")	NS-25060 0.9Nm	NK-T7

► Accessories - Set & Spare >>

Set	Ergo Nut			High Strength Ergo Pin			L-Key	Ergo Spanner		
* Nut, pin & L-key are included. ER	Parts No.	Parts No.	ød	Pitch	Torque	Parts No.	L	Torque	Parts No.	Parts No.
ER16	99816-M19S	99816-M19	25 (0.948")	M19xP1.0	30 Nm	NS-50025	25 (0.948")	5 Nm	NK-LW3	99816-SP28
	99816-M22S	99816-M22	28 (1.102")	M22xP1.5	30 Nm	NS-50028	28 (1.102")	5 Nm		

i-Center Spotting & Countersink

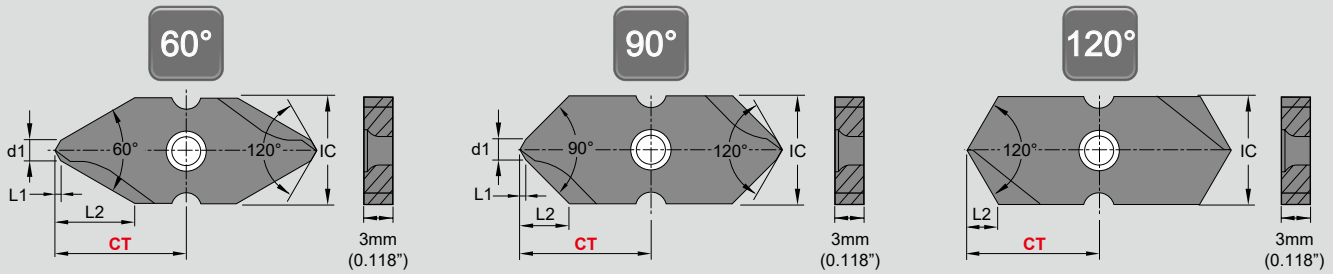

▶ Insert >>

- Double-edged cutting, fully ground insert for improving machining stability.
- NC2057: Universal grade for all kind of steel.
- Each insert has 2 cutting edges.

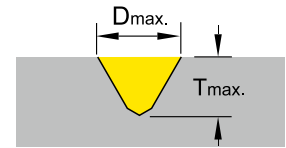

IC	Angle	Parts No.	Coating	Grade	Dimensions			Dmax.	Tmax.	CT ±0.025 (.001")
					d1	L1	L2			
10 (.394")	60°	I9MT1003CT060-NC2057	AlTiN+ TiSiN	P35	2 (.079")	0.58 (.023")	7.5 (.296")	10 (.394")	7.5 (.295")	12.35 (.486")
	90°	I9MT1003CT090-NC2057					4.6 (.181")	10 (.394")	4.6 (.181")	
	120°	I9MT1003CT120-NC2057					-	-	2.9 (.114")	

▶ Basic Holder >>

- G6.3 / 10,000 r.p.m.
- With internal coolant.

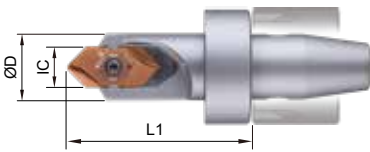
IC	Parts No.	Basic Holder	L1	øD	Screw	Key
10 (.394")	99816-IC10BH		16 (.630")	45 (1.772")	NS-25060 0.9Nm	NK-T7

▶ Accessories - Set & Spare >>

Set		Ergo Nut				High Strength Ergo Pin			L-Key	Ergo Spanner
										
ER	Parts No.	Parts No.	Ød	Pitch	Torque	Parts No.	L	Torque	Parts No.	Parts No.
ER16	99816-M19S	99816-M19	25 (0.948")	M19xP1.0	30 Nm	NS-50025	25 (0.948")	5 Nm	NK-LW3	99816-SP28
	99816-M22S	99816-M22	28 (1.102")	M22xP1.5	30 Nm	NS-50028	28 (1.102")	5 Nm		

* Nut, pin & L-key are included.

5

Ergo

i-Center Cutting Data

- Internal coolant is recommended.
- Middle value of feed rate is recommended for starting.
- Using your “d1” value and cutting speed Vc from the data sheet, calculate spindle speed “S”(r.p.m).
- “ F” feed rate per minute $F = S \times f = IPR \times r.p.m.$

▶ Indexable Center Drill >>

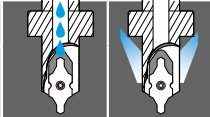
Workpiece material		d1 (Pilot Diameter)			
		Ø1 ~ Ø1.25mm (.039" ~ .049")	Ø1.6 ~ Ø3.15 (.063" ~ .124")		
P Carbon steel C<0.3%	SFM	21 ~ 125	30 ~ 255	●	○
	IPR inch/rev.	.0008 ~ .0020	.0012 ~ .0024		
P Carbon steel C>0.3%	SFM	21 ~115	30 ~ 230	●	○
	IPR inch/rev.	.0008 ~ .0020	.0012 ~ .0020		
P Low alloy steel C<0.3%	SFM	21 ~100	30 ~200	●	○
	IPR inch/rev.	.0004 ~ .0016	.0008 ~ .0020		
P High alloy steel	SFM	11 ~75	15 ~155	●	○
	IPR inch/rev.	.0004 ~ .0008	.0004 ~ .0016		
M Stainless steel	SFM	11 ~ 35	15 ~75	●	○
	IPR inch/rev.	.0001 ~ .0004	.0002 ~ .0008	≥ 5 bar	
N Non-ferrous metal	SFM	62 ~255	80 ~ 515	●	○
	IPR inch/rev.	.0004 ~ .0012	.0004 ~ .0016		

● Best ○ Possible

5

Ergo

▶ Spotting & Countersink >>

Workpiece Material	SFM	Spotting			Countersink	
		IPR (inch/rev.)			SFM	IPR (inch/rev.)
		60°	90°	120°		
P Carbon steel C<0.3%	410 ~ 820	.0016" ~ .008"	.006" ~ .010"	.004" ~ .012"	410 ~ 820	.008" ~ .020"
P Carbon steel C>0.3%	330 ~ 730	.0016" ~ .008"	.004" ~ .002"	.004" ~ .012"	330 ~ 730	.008" ~ .016"
P Low alloy steel C<0.3%	330 ~ 660	.0012" ~ .006"	.003" ~ .008"	.004" ~ .010"	330 ~ 660	.006" ~ .016"
P High alloy steel	260 ~ 590	.0012" ~ .005"	.003" ~ .008"	.004" ~ .010"	260 ~ 590	.004" ~ .012"
M Stainless steel	200 ~ 410	.0008" ~ .004"	.002" ~ .005"	.003" ~ .006"	200 ~ 410	.003" ~ .012"
N Non-ferrous metal	500 ~ 1050	.0016" ~ .008"	.004" ~ .010"	.004" ~ .012"	500 ~ 1050	.008" ~ .020"

X060 Micro Spotting & Engraving



► Micro Spotting >>

• Radius Angled Form

Angle	Parts No.	Coating	Grade		Dimensions			Wmin.	Wmax.	Tmax.	
					L	S	Re				
90°	X060A90W010R	NC2032	TiAlN	K20F		6 (0.236")	2.05 (0.081")	0.02 (0.0008")	0.1 (0.004")	1.1 (0.043")	0.5 (0.020")
		XP9001	Uncoated								
120°	X060A120W010R	NC2032	TiAlN	K20F		6 (0.236")	2.05 (0.081")	0.02 (0.0008")	0.1 (0.004")	2.53 (0.100")	0.7 (0.028")
142°	X060A142W010R	NC2032	TiAlN	K20F							

► Engraving >>

• Radius Angled Form

Angle	Parts No.	Coating	Grade		Dimensions			Wmin.	Wmax.	Tmax.	
					L	S	Re				
30°	X060A30W020R	NC2032	TiAlN	K20F		6 (0.236")	2.05 (0.081")	0.04 (0.0015")	0.20 (0.008")	0.52 (0.020")	0.6 (0.024")
	XP9001	Uncoated									
45°	X060A45W020R	NC2032	TiAlN	K20F		6 (0.236")	2.05 (0.081")	0.04 (0.0015")	0.20 (0.008")	0.86 (0.034")	0.8 (0.031")
			XP9001								
60°	X060A60W020R	NC2032	TiAlN	K20F		6 (0.236")	2.05 (0.081")	0.04 (0.0015")	0.20 (0.008")	1.36 (0.054")	1.0 (0.039")
			XP9001								
90°	X060A90W020R	NC2032	TiAlN	K20F		6 (0.236")	2.05 (0.081")	0.04 (0.0015")	0.20 (0.008")	2.20 (0.087")	1.0 (0.039")
			XP9001								

• Radius Form

Angle	Parts No.	Coating	Grade		Dimensions			R max. Depth	Wmax.	Tmax.	
					L	S	Re				
30°	X060A30R020	NC2032	TiAlN	K20F		6 (0.236")	2.05 (0.081")	0.2 (0.008")	0.15 (0.006")	0.63 (0.025")	0.6 (0.024")
		XP9001	Uncoated								
45°	X060A45R020	NC2032	TiAlN	K20F		6 (0.236")	2.05 (0.081")	0.2 (0.008")	0.12 (0.005")	0.93 (0.037")	0.8 (0.031")
		XP9001	Uncoated								
60°	X060A60R020	NC2032	TiAlN	K20F		6 (0.236")	2.05 (0.081")	0.2 (0.008")	0.1 (0.004")	1.39 (0.055")	1.0 (0.039")
		XP9001	Uncoated								

► More & Cutting Data >>

- For more micro spotting insert & cutting data, please refer to page 2-23.
- For more engraving insert & cutting data, please refer from page 3-75.

X060 Deburring



► Deburring >>

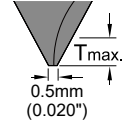

Angle	Part No.	Coating	Grade	Flutes	Diagram	Dimensions		Tmin.	Tmax.
						L	S		
60°	X060A60T3-NC2032	TiAlN	K20F	3		6 (0.236")	2.8 (0.110")	0.1 (0.004")	0.9 (0.035")
	X060A60T3-XP9001	Uncoated							
90°	X060A90T3-NC2032	TiAlN	K20F	3		6 (0.236")	2.8 (0.110")	0.1 (0.004")	0.9 (0.035")
	X060A90T3-XP9001	Uncoated							
60°	X060A60T6-NC2032	TiAlN	K20F	6		6 (0.236")	2.0 (0.079")	0.1 (0.004")	1.8 (0.071")
90°	X060A90T6-NC2032							0.5 (0.020")	1.5 (0.059")

► Basic Holder >>

- For entire X060 engraving, spotting and deburring inserts.
- G4.0 / 20,000 r.p.m.

Parts No.	Basic Holder	L1	Screw	Key
99816-X060		22 (0.866")	NS-22044 0.9Nm	NK-T7



► Accessories - Set & Spare >>

Set		Ergo Nut				High Strength Ergo Pin			L-Key	Ergo Spanner
ER	Parts No.	Parts No.	Ød	Pitch	Torque	Parts No.	L	Torque	Parts No.	Parts No.
ER16	99816-M19S	99816-M19	25 (0.948")	M19xP1.0	30 Nm	NS-50025	25 (0.948")	5 Nm	NK-LW3	99816-SP28
	99816-M22S	99816-M22	28 (1.102")	M22xP1.5	30 Nm	NS-50028	28 (1.102")	5 Nm		

► Cutting Data >>

- For Deburring, please refer to page 4-83.

Multi-Functional Tool Spotting & Chamfering



► Inserts >>

Angle	Parts No.	Coating	Grade		Dimensions			Dmax.	Tmax.
					L	S	Re		
60°	V06006T1W06-NC2071	TiN	K20F		6.35 (0.250")	2.0 (0.079")	0.2 (0.008")	2.7 (0.106")	2.0 (0.079")
	V06006T1W06-NC2032	TiAlN							
	V06006T1W06-NC9031	TiN							
90°	N9MT080208CT-NC40	TiN	K20F		8.31 (0.327")	2.38 (0.094")	0.8 (0.031")	10 (0.394")	4.5 (0.177")
	N9MT080204CT-NC40	TiN					0.4 (0.016")	10 (0.394")	4.5 (0.177")
	N9MT080204CT-NC10	TiAlN					0.4 (0.016")	10 (0.394")	4.5 (0.177")
90°	N9MT11T3CT-NC40	TiN	P35		11.11 (0.433")	3.97 (0.156")	0.8 (0.031")	14 (0.551")	7 (0.276")
	N9MT11T3CT-NC10	TiAlN	K10F				0.3 (0.012")	14 (0.551")	7 (0.276")

► Basic Holder >>

• G6.3 / 10,000 r.p.m.

Parts No.	Basic Holder	Insert Type	L1	Screw	Key
99816-V060		V060...		NS-22044 0.9Nm	NK-T7
99816-610		N9MT0802...	22 (0.866")	NS-30055 2.0 Nm	NK-T8
99816-614		N9MT11T3...		NS-35080 2.5 Nm	NK-T15

► Accessories - Set & Spare >>

Set		Ergo Nut				High Strength Ergo Pin			L-Key	Ergo Spanner
* Nut, pin & L-key are included.										
ER	Parts No.	Parts No.	Ød	Pitch	Torque	Parts No.	L	Torque	Parts No.	Parts No.
ER16	99816-M19S	99816-M19	25 (0.948")	M19xP1.0	30 Nm	NS-50025	25 (0.948")	5 Nm	NK-LW3	99816-SP28
	99816-M22S	99816-M22	28 (1.102")	M22xP1.5	30 Nm	NS-50028	28 (1.102")	5 Nm		

► Cutting Data >> please refer to page 3-76 for 60° insert, page 2-47 for 90° insert.

45° Chamfer Mill

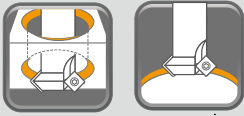

► Inserts >>

Parts No.	Coating	Grade		Dimensions		
				L	S	Re
N9GX04T002	NC2032	AlTiN		4.0 (0.157")	1.8 (0.070")	0.2 (0.008")
	NC9071	TiN				

► Basic Holder >>

- For front and back chamfering.
- G6.3 / 10,000 r.p.m.

Parts No.	Basic Holder	L1	No. of teeth	Screw	Key
99816-C10		22 (0.866")	2	NS-18037 0.6Nm	NK-T6



► Accessories - Set & Spare >>

Set		Ergo Nut				High Strength Ergo Pin			L-Key	Ergo Spanner
<p>* Nut, pin & L-key are included.</p>										
ER	Parts No.	Parts No.	Ød	Pitch	Torque	Parts No.	L	Torque	Parts No.	Parts No.
ER16	99816-M19S	99816-M19	25 (0.948")	M19xP1.0	30 Nm	NS-50025	25 (0.948")	5 Nm	NK-LW3	99816-SP28
	99816-M22S	99816-M22	28 (1.102")	M22xP1.5	30 Nm	NS-50028	28 (1.102")	5 Nm		

► Cutting Data >> please refer to page 4-89.

Power Mill



► Inserts >>

- U type insert is fully ground for reducing the cutting resistance during the cutting, best choice for long shank cutter.
- H type with high positive rake angle, shape edge.

Parts No.	Coating	Grade	Insert	Dimensions					
				Re	Ap	L	W	S	
A9GT060201H	NC2033	TiAlN		0.1 (0.004")	5 (0.197")	6.5 (0.259")	4 (0.157")	2.45 (0.096")	
	NC9031	TiN							
A9GT060202H	NC2033	TiAlN		0.2 (0.008")					
	NC9031	TiN		0.2 (0.008")					
A9GT060205H	NC2033	TiAlN		0.5 (0.020")					
	NC9031	TiN		0.5 (0.020")					
A9GT060201U	NC2032	TiAlN		K20F					0.1 (0.004")
A9GT060202U	NC2032	TiAlN		K20F					0.2 (0.008")
A9GT060205U	NC2032	TiAlN		K20F					0.5 (0.020")

► Basic Holder >>

- G6.3 / 10,000 r.p.m.
- Customized cutter is available on request. Please refer to page 5-107.

ER Taper	Parts No.	ØD	Basic Holder	L1	No. of teeth	α°	Screw / Key	
ER11	99811-10A06	10 (0.394")		14 (0.551")	2	5	NS-18037 0.6Nm / NK-T6	
	99811-12A06	12 (0.472")			2	4		
	99816-10A06	10 (0.394")			2	5		
	99816-12A06	12 (0.472")			2	4		
ER16 (with internal coolant)	99816-16A06	16 (0.630")			14.5 (0.571")	3		2
	99816-20A06	20 (0.787")				3		2
	99816-25A06	25 (0.984")				4		1.3
ER20	99816-32A06	32 (1.260")			26 (1.024")	4		1
	99820-12A06	12 (0.472")	2			4		
	99820-16A06	16 (0.630")	3			2		
	99820-20A06	20 (0.787")	3			2		
	99820-25A06	25 (0.984")	4			1.3		
ER16	99816-10A06-32L	10 (0.394")		32 (1.260")	2	5		
	99816-10A06-40L	10 (0.394")			2	5		
ER20	99820-10A06-40L	10 (0.394")		40 (1.575")	2	5		
	99820-12A06-40L	12 (0.472")			2	4		

5

Ergo

► Accessories - Set & Spare >>

Set		Ergo Nut				High Strength Ergo Pin			L-Key	Ergo Spanner
* Nut, pin & L-key are included.										
ER	Parts No.	Parts No.	Ød	Pitch	Torque	Parts No.	L	Torque	Parts No.	Parts No.
ER11	99811-M13S	99811-M13	19 (0.748")	M13xP0.75	12 Nm	NS-40019	19 (0.748")	3 Nm	NK-LW25	99811-SP20
ER16	99816-M19S	99816-M19	25 (0.948")	M19xP1.0	30 Nm	NS-50025	25 (0.948")	5 Nm	NK-LW3	99816-SP28
	99816-M22S	99816-M22	28 (1.102")	M22xP1.5	30 Nm	NS-50028	28 (1.102")	5 Nm		
ER20	99820-M24S	99820-M24	34 (1.339")	M24xP1.0	45 Nm	NS-60033	33 (1.299")	6 Nm	NK-LW4	99820-SP36
	99820-M25S	99820-M25	34 (1.339")	M25xP1.5	45 Nm	NS-60033	33 (1.299")	6 Nm		

► Cutting Data >>

Workpiece Material	SFM	fz (inch/tooth)			Grade of insert	
Carbon steel	260 ~ 500	0.0012" ~ 0.0028"	0.059"	0.118"	0.039"	
P Low-alloy steel C < 0.3%						NC2033 NC2032
High-alloy steel	200 ~ 410	0.0008" ~ 0.0024"	0.039"	0.098"	0.039"	NC2033 NC2032
M Stainless steel	200 ~ 410	0.0004" ~ 0.0020"	0.020"	0.079"	0.039"	NC9031 NC2033
N Non-ferrous metal	660 ~ 1640	0.0008" ~ 0.0028"	0.079"	0.157"	0.079"	NC9031 NC2032

► Performance >>

- Result - Surface Quality

Ergo power mill Ø10 (0.394")	Indexable milling cutter Ø10 (0.394")	Carbide end mill Ø10 (0.394")
VB=0.04 mm (0.0016") No chipping 😊	VB=0.04 mm (0.0016") Partial chipping 😐	VB=0.20 mm (0.0079") Extensive chipping 😞

- Measure VB value (tool wearing) and chipping condition

Surface finishing is fine 😊	About 50% surface finishing is rough 😐	About 80% surface finishing is rough 😞

5

Ergo

Ergo Setter TP

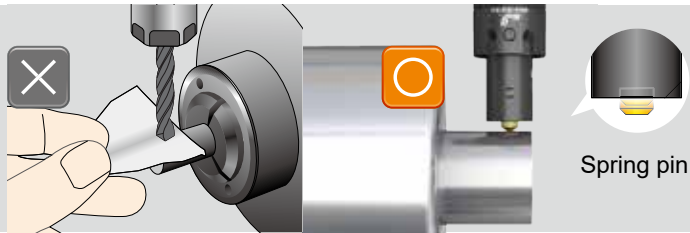

▶ Quick and simple tool length setting >>

▶ Tool length setter >>

- Ergo setter is an easy tool length recorder while setting the tool length on swiss type automatic lathe and CNC turning centers.
- Reduce machine downtime, prevent insert and workpiece from damage.

Parts No.	Illustration	L-Key
99816-TP	 Focusing edge (For Tool Presetter)	NK-LW15 (2 Nm)

▶ Accessories - Set & Spare >>

Set		Ergo Nut				High Strength Ergo Pin			L-Key	Ergo Spanner
* Nut, pin & L-key are included.										
ER	Parts No.	Parts No.	Ød	Pitch	Torque	Parts No.	L	Torque	Parts No.	Parts No.
ER16	99816-M19S	99816-M19	25 (0.948")	M19xP1.0	30 Nm	NS-50025	25 (0.948")	5 Nm	NK-LW3	99816-SP28
	99816-M22S	99816-M22	28 (1.102")	M22xP1.5	30 Nm	NS-50028	28 (1.102")	5 Nm		

▶ Setting process >>

• Step-1

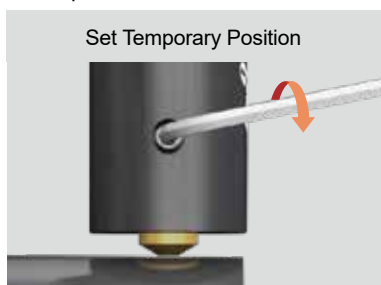

- 1-1: Move the setter tip to touch the center-top of workpiece.
- 1-2: Press spring pin 1~2 mm down.
- 1-3: Tighten screw to fix spring pin, and get a temporary length of setter.
- 1-4: Input the temporary length value to the CNC controller.

• Step-2

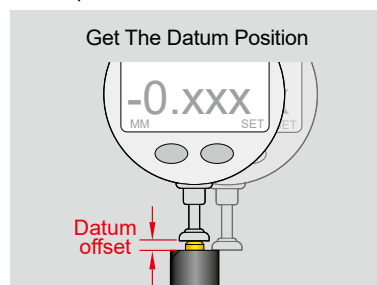

- 2-1: The offline measures the datum offset of setter by height gauge.
- 2-2: Input datum offset to CNC controller.

• Step-3

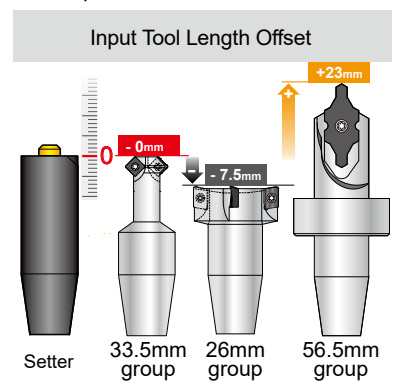

- 3-1: Choose an Ergo tool to install, and input the offset value to CNC controller directly.

5

Ergo

Assembly Steps

! Make sure all parts are clean while re-assembly or change tool

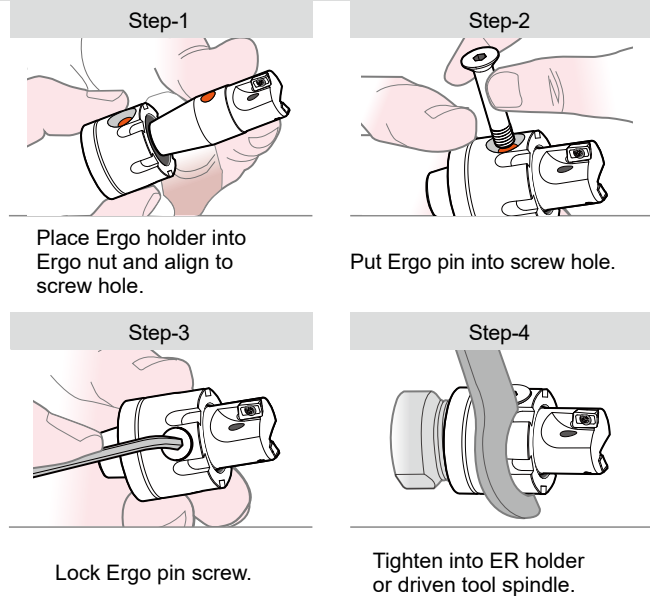
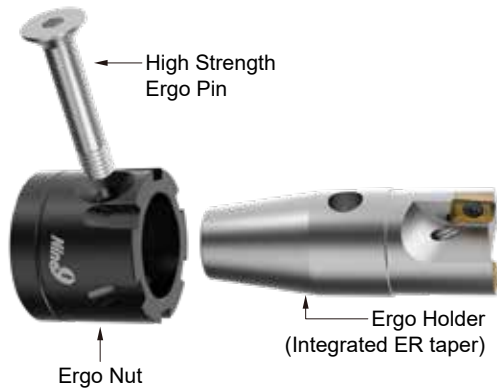

► As long as it complies with ER11, 16, 20 and ER25 standard, you can use Ergo system. >>



- Quick change and ultrashort over all tool length.
- Apply on any kinds of driven tools and collet chucks.

5
Ergo

► Performance >>

Material	Testing length	Tool overhang	Machine: HAAS VM-3, BT40 / 22.5KW					
			SFM	S (r.p.m.)	f (inch/z)	F (IPM)	Ap (inch)	Ae (inch)
S50C (Carbon steel)	78.74"	6.772" (by ER collet chuck)	260	2500	0.0012"	3	0.039"	0.236"
Tool	Tool Wear		Surface Roughness			Cutting Noise		
Ergo Power Mill	[Bar chart showing low wear]		[Bar chart showing low roughness]			[Bar chart showing low noise]		
Indexable cutter	[Bar chart showing high wear]		[Bar chart showing high roughness]			[Bar chart showing high noise]		
Carbide end mill	[Bar chart showing high wear]		[Bar chart showing high roughness]			[Bar chart showing high noise]		

Ergo Sets For your first ordering

► The insert is not included >>

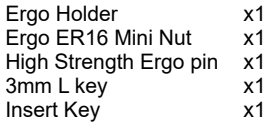
Nut	Series	Parts No.	Contents
With ER16 Mini Nut (M19 x 1.0 P)	i-Center	99816-IC10BH-M19S	 Ergo Holder x1 Ergo ER16 Mini Nut x1 High Strength Ergo pin x1 3mm L key x1 Insert Key x1
	X060 - Micro Spotting, Engraving & Deburring	99816-X060-M19S	
	Multi-Functional Tool - Spotting & Chamfering	99816-V060-M19S	
		99816-610-M19S	
	Chamfer Mills	99816-614-M19S	
		99816-C10-M19S	
	Power Mills	99816-10A06-M19S	
		99816-12A06-M19S	
		99816-16A06-M19S	
		99816-20A06-M19S	
		99816-25A06-M19S	
		99816-32A06-M19S	
	Tool Length Setter	99816-TP-M19S	
	With ER16 Nut (M22 x 1.5 P)	i-Center	
X060 - Micro Spotting, Engraving & Deburring		99816-X060-M22S	
Multi-Functional Tool - Spotting & Chamfering		99816-V060-M22S	
		99816-610-M22S	
Chamfer Mills		99816-614-M22S	
		99816-C10-M22S	
Power Mills		99816-10A06-M22S	
		99816-12A06-M22S	
		99816-16A06-M22S	
		99816-20A06-M22S	
		99816-25A06-M22S	
		99816-32A06-M22S	
Tool Length Setter		99816-TP-M22S	

5

Ergo

* The insert is not included.

* The insert is not included.

Enquiry Form

► **Company >>**

► **Challenge or improvement >>**

• The following information should be checked while discussing with customer.

Machine		Current tool	
Machine Type		<input type="checkbox"/> HSS <input type="checkbox"/> Solid Carbide	
Spindle Speed	Max. r.p.m.	Cutting Speed	m/min. SFM
Power of Spindle motor	<input type="checkbox"/> KW <input type="checkbox"/> HP	Others	
Coolant supply	<input type="checkbox"/> NO <input type="checkbox"/> If yes, <input type="checkbox"/> External <input type="checkbox"/> Internal	Feed Rate	mm/rev. inch/rev.
Workpiece Material	bar(psi)		

► **ER Taper-shank dimensions >>**

• MOQ: 2 pcs / Lead Time: 10 ~ 12 Weeks.

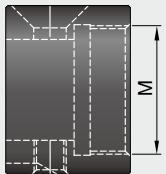
Style	
<input type="checkbox"/> A	<input type="checkbox"/> B <input type="checkbox"/> C
Cutter Dia. : (ØDc)	
L1 : (See chart for Max.)	θ : E :
Internal Coolant	<input type="checkbox"/> Yes <input type="checkbox"/> No
ER Nut	<input type="checkbox"/> N9ER16-M19 <input type="checkbox"/> N9ER16-M22 <input type="checkbox"/> N9ER20-M24 <input type="checkbox"/> N9ER20-M25 <input type="checkbox"/> N9ER25-M32
Nut Specifications 	M
	<input type="checkbox"/> ER16 M19xP1.0
	<input type="checkbox"/> ER16 M22xP1.5
	<input type="checkbox"/> ER20 M24xP1.0
	<input type="checkbox"/> ER20 M25xP1.5
<input type="checkbox"/> ER25 M32xP1.5	

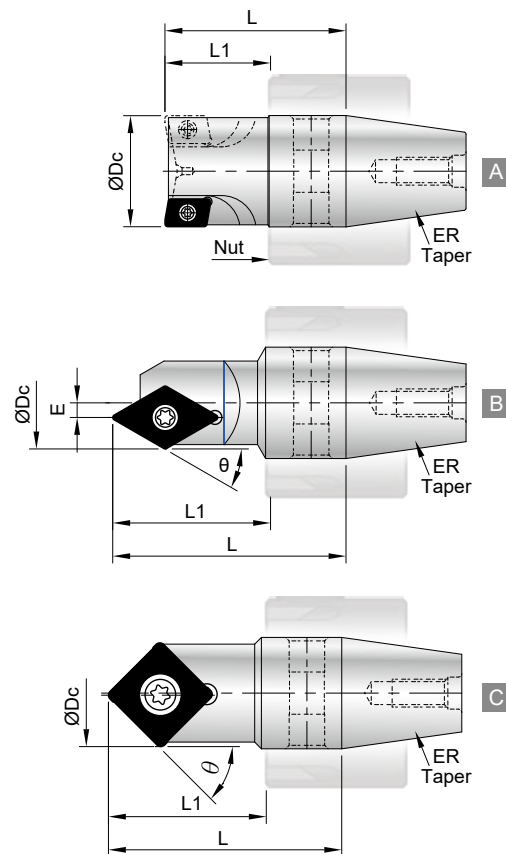

ER Taper Specifications			
ØDc	L1 Max.	L Max.	ER Taper
10 ~ 32	22	34	ER16
	26.5	40	ER20
	30.5	50	ER25

5

Ergo